

# PS2-1800 C-SJ1-25

Solar Submersible Pump System for 4" wells

## System Overview

Head max. 140 m  
Flow rate max. 3.0 m³/h

## Technical Data

### Controller PS2-1800

- Controlling and monitoring
- Control inputs for dry running protection, remote control etc.
- Protected against reverse polarity, overload and overtemperature
- Integrated MPPT (Maximum Power Point Tracking)
- Battery operation: Integrated low voltage disconnect
- Integrated Sun Sensor

Power max. 1.8 kW  
Input voltage max. 200 V  
Optimum Vmp\*\* > 102 V  
Motor current max. 14 A  
Efficiency max. 98 %  
Ambient temp. -40...50 °C  
Enclosure class IP68

### Motor ECDRIVE 1200-C / ECDRIVE 1800-C

- Maintenance-free brushless DC motor
- Water filled
- Premium materials, stainless steel: AISI 304/316
- No electronics in the motor

Rated power 1.7 kW  
Efficiency max. 92 %  
Motor speed 900...3,300 rpm  
Insulation class F  
Enclosure class IP68  
Submersion max. 150 m

### Pump End PE C-SJ1-25

- Non-return valve
  - Premium materials, stainless steel: AISI 304
  - Centrifugal pump
- Efficiency max. 49 %

### Pump Unit PU1800 C-SJ1-25 (Motor, Pump End)

Borehole diameter min. 4,0 in  
Water temperature max. 50 °C

## Standards



2006/42/EC, 2004/108/EC, 2006/95/EC

IEC/EN 61702:1995, IEC/EN 62253 Ed.1

The logos shown reflect the approvals that have been granted for this product family. Products are ordered and supplied with the approvals specific to the market requirements.

\*\*Vmp: MPP-voltage under Standard Test Conditions (STC): 1000 W/m² solar irradiance, 25 °C cell temperature



## PS2-1800 C-SJ1-25

Solar Submersible Pump System for 4" wells

### Pump Chart

Vmp\* > 102 V

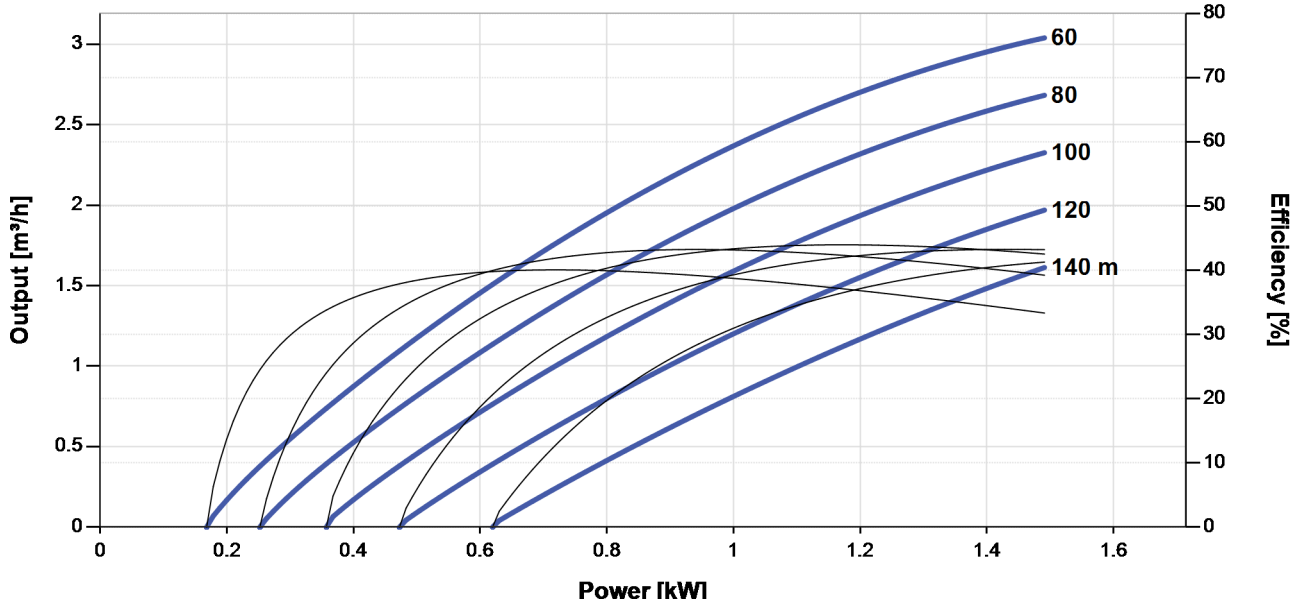

### Dimensions and Weights

#### Controller

H1 = 352 mm  
 H2 = 333 mm  
 W1 = 207 mm  
 W2 = 170 mm  
 W3 = 164 mm  
 D1 = 124 mm

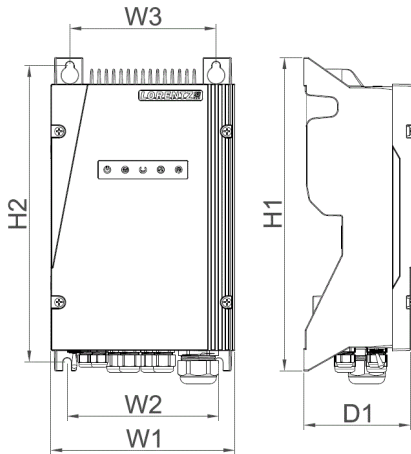

#### Pump Unit

A = 881 mm  
 B = 185 mm  
 C = 696 mm  
 D = 96 mm  
 E = 98 mm  
 S = 1.25 in

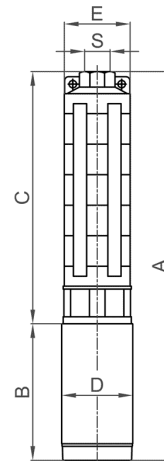

	Net weight
Controller	6.0 kg
Pump Unit	16 kg
Motor	7.0 kg
Pump End	9.0 kg

\*Vmp: MPP-voltage under Standard Test Conditions (STC): 1000 W/m² solar irradiance, 25 °C cell temperature

